

# Before You Install

Sept. 2016

There is an incredible range of trailers with varying types of winch posts and platforms. In Australia and America there are a wide range of choices from trailer suppliers, however in some other countries, choice is poor and adjustability is limited or not available. To help here the following gives the ideal set-up you need for a range of boat types. You can print this off and take it to your trailer supplier with the comment - "this is what I need mate, what have you got in your range that suits?".

**Odd set-ups .....should be more like**

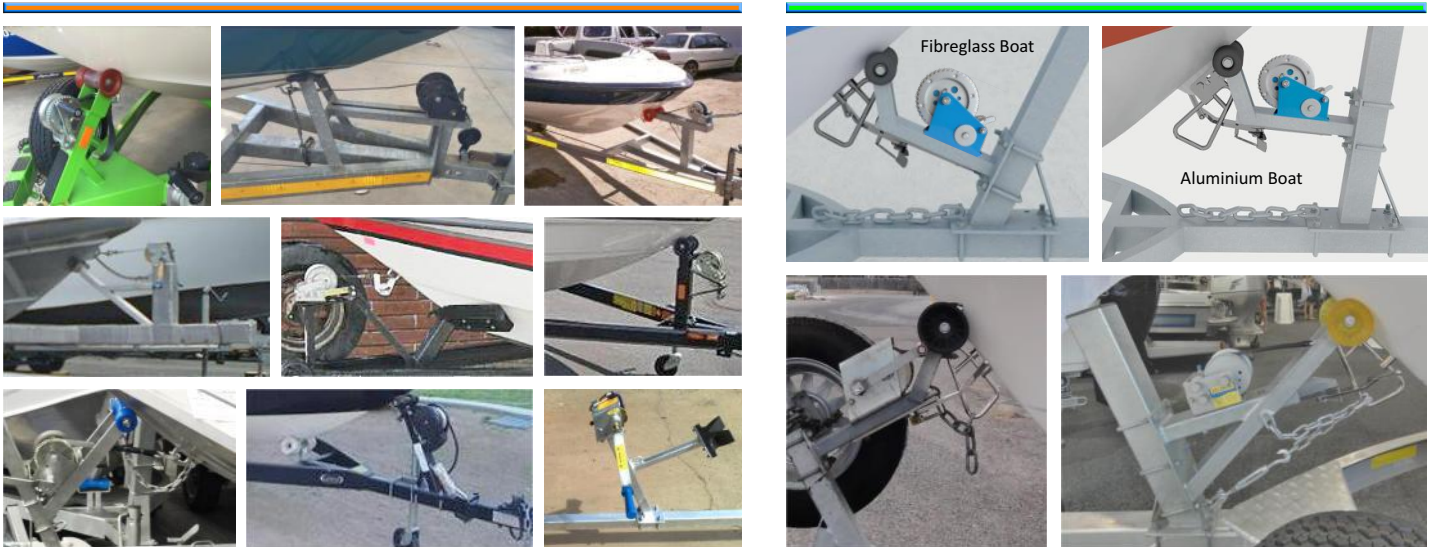

- 1** Key Variables - How to Sort Out Issues..... Page 2
- 2** The Best Angle for the Snare to hit the latch ..... Page 3
- 3** Best Angle - How to measure it ..... Page 4
- 4** Altering the Snare to Latch angle - using Wedge Kit option..... Page 5
- 5** No support for your Latch front bolt - Use Latch Support ..... Page 5-6
- 6** Roller doesn't reach out far enough - Roller Extender option ..... Page 6
- 7** Changing the Winch Post or Winch Platform ..... Page 7
- 8** Catamarans ..... Page 7
- 9** Use a Large Heavy Duty Snare ?..... Page 8
- 10** Examples ..... Page 9-10

|                   |                            |                      |
|-------------------|----------------------------|----------------------|
| <b>Contact Us</b> | <b>Australia</b>           | <b>International</b> |
| Phone             | 08 8554 7214               | + (61) 8 8554 7214   |
| Mob/Cell          | 0402 079 660               | +(61) 402 079 660    |
| Fax               | 08 8554 7207               | +(61) 8 8554 7207    |
| Skype             | geoffrey.c.davis           |                      |
| Email             | boatlatch@internode.on.net |                      |



Patented

For more information:-  
[www.boatlatch.com](http://www.boatlatch.com)



**1 Key Variables - how to sort out issues**

You may not need to worry many of these these. Just depends on your present boat/trailer set-up.

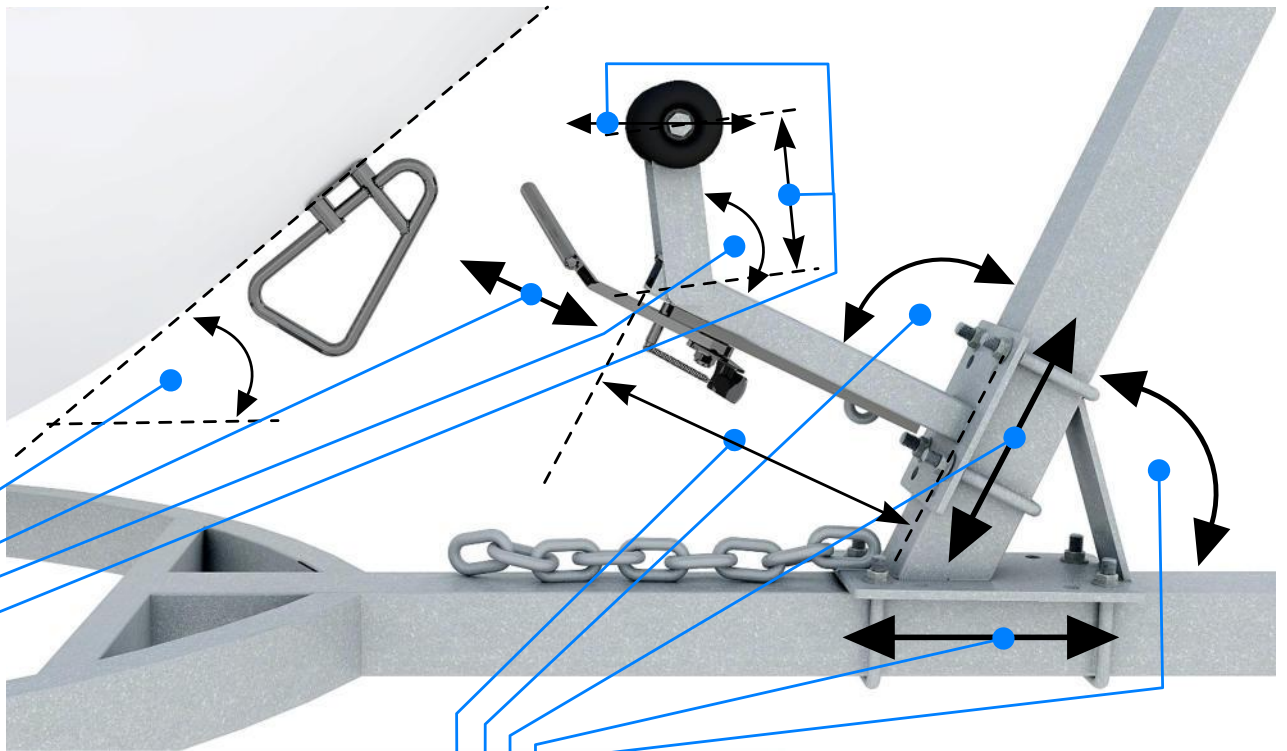

● **Roller Supports - Length**  
If they are a bit short you can use the Roller Extender **6**

● **Roller Supports - Angle**  
Short Roller supports may mean you cannot hold the boat back, and the Latch can hit the boat or the Snare hits the front of the Winch Support. Solution - use the Roller Extender **6**

● **Latch - forward/Rear adjustment**  
A range of holes allows adjustment - forward & back. Can be limited if the Winch Platform length is short. Use Latch Support **5**

● **Bow Angle**  
Typical shown here - but there are other extremes out there. This throws out the latch/Snare angle. See **2** & **4** to compensate.

● **Winch Post - Angle**  
This is shown at an angle of 65° which for Fibreglass boats is normally OK. For Towing Eye (Aluminium) boats moving up to about 85° (or replace post) will usually sort out problems, OR use the ..... Roller Extender **6** to compensate.

● **Winch Post - Forward/Back**  
When installing - start with the winch Post back out of the way. When adjusting - move the Winch Post forward with the Roller/Wedge up against the bow.

● **Winch Platform - Height**  
Move up/down to get the roller/wedge to a point just above the Snare top. You want to 'wedge' the boat front so it cannot move up or down on the trailer.

● **Winch Platform - Angle**  
You can adjust this using **4** the Wedge Kit ± 14° up or down.

● **Winch Platform - Length**  
Some Winch platforms are short. This robs you of adjustable length, and you may not be able to mount the front bolt on the Latch. You can extend this by using the Latch Support (part of the Wedge Kit).

## 2 The Best Angle for the Snare to hit the Latch

The key issue in getting good performance with the L & R Boat Latch is to have the correct angle where the Latch meets the Snare.

You need to roughly measure this angle. See guide .... next page.

There are some very odd winch plate and winch posts out there.

If the angle is not right you can adjust it using the "Wedge Kit" option or change the winch plate or the winch post.

To help you work out the angles we have printed some on the next page.

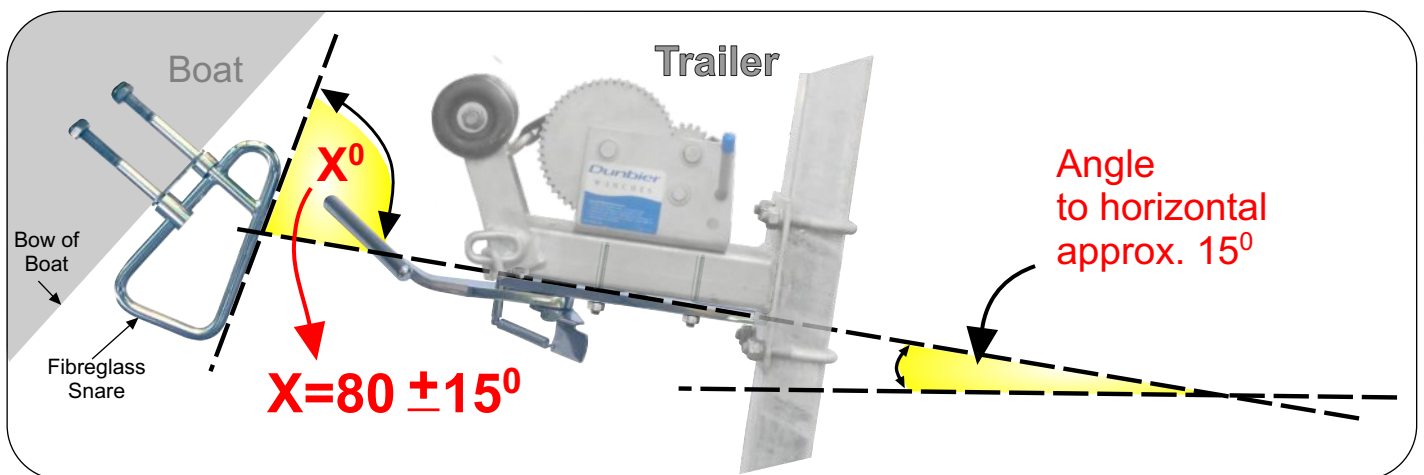

If you do not have the right angle then the latch angle is the thing to adjust.

### How to change the Latch angle....

- [1] Use the L & R 'Wedge Kit' which allows you to alter the angle in either direction by 14°  
See the Brochure "The 'Wedge' option" on website - under "Installation - detail version"
- [2] OR change the winch post or winch platform for another from your local trailer supplier for one that has a more suitable angle.

### Examples

Here are two where the 'Wedge' would sort out the angle problem. The ski boats are about 58 to 62° which is too low, and the 'Wedge' will bring them nicely into the right operating range.



**3 Best Angle - How to measure it**

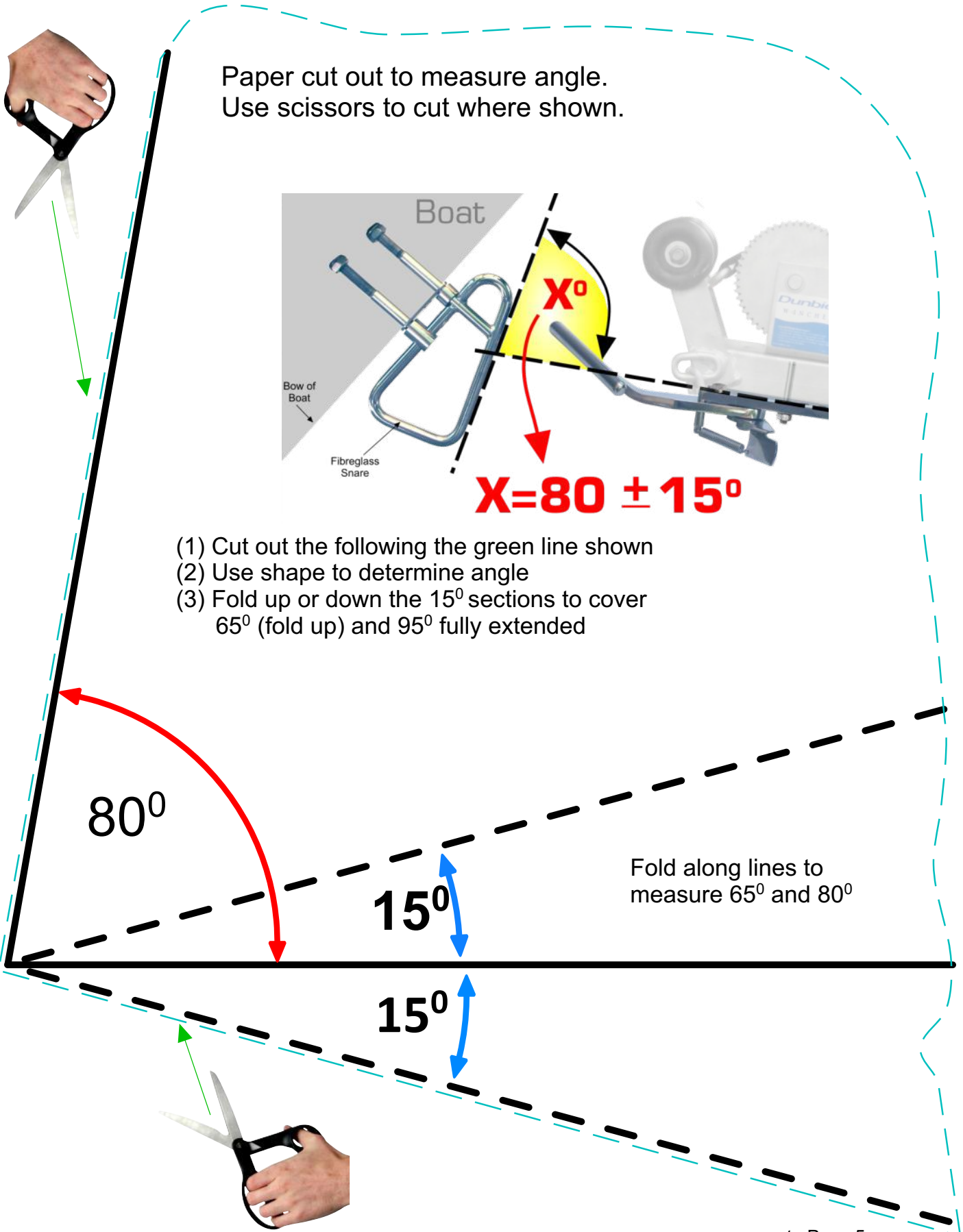

**4 Altering the Snare to Latch angle - Using Wedge Kit option**

Where the angle of the Snare to the Latch is altered using the L & R 'Wedge'. This allows you to vary the existing angle by 14° up or down. This also has the benefit of giving a proper mount point for the front bolt.

**Tilt 14 degrees UP** so an an angle of 51° could be moved up to 65° - just within usable range.

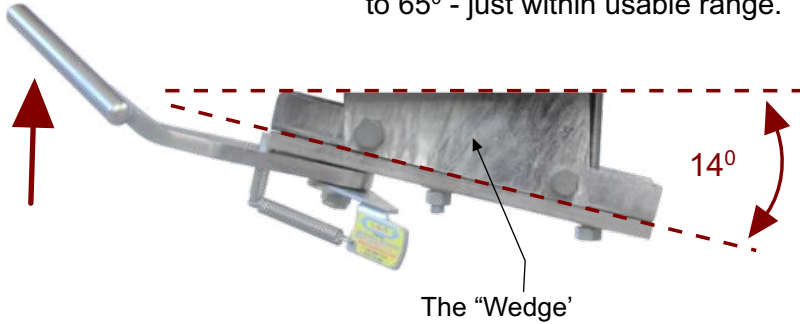

"Wedge" side plates



**Tilt 14 degrees DOWN** an angle of 109° could be moved down to 95° - the top of a usable range.

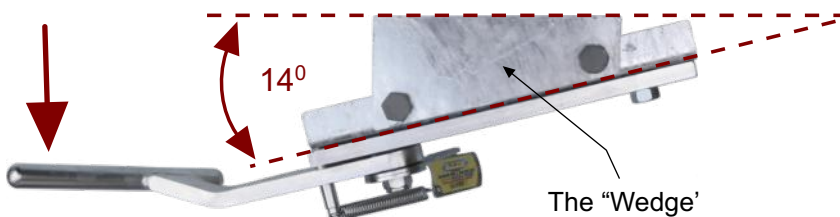

The 'Latch Support'



The 'Latch Support' can be mounted at an angle using the 'Wedge' side plates. This provides a simple way of adjusting the angle that the Latch hits the Snare. A fast and simple way of coping with some of the more unusual trailers out there that do not have a suitable surface at the right angle to mount the Latch.

**5 No support for your Latch front bolt ? - Use Latch Support**

Where the front of the latch is sitting out 'in space' with no backing support and no surface to mount the front latch bolt.

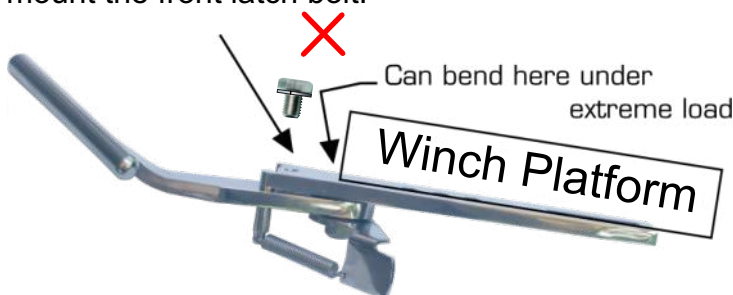

In these circumstances the front of the latch can bend in extreme situations and ruin its functionality.

**5 Latch Support - continued**

**The 'Latch Support'**



You can also combine this with the wedge plates to adjust the angle as well if required. The Latch Support comes as a kit together with the Wedge plates.

Note - this front bolt needs to be installed otherwise you will void the warranty.



**6 Roller doesn't reach out far enough - Roller Extender option**

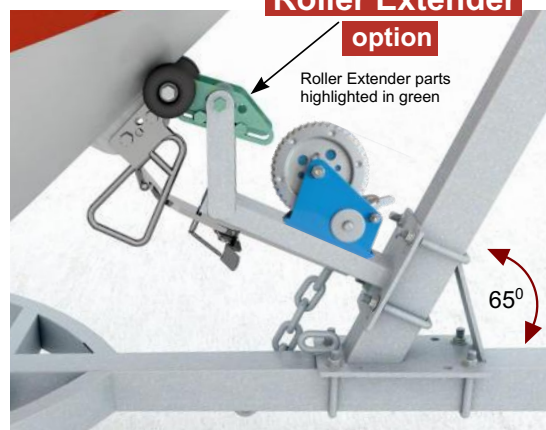

**Roller Extender option**

**Adjustment -**

Horizontal Adjustment  
48 mm max.  
(4 hole positions)

Vertical up/down  
40 mm roller support arms  
Rear hole 121 mm (4")  
Front hole 24 mm (1")

50 mm roller support arms  
Rear Hole 104 mm (4.8")  
Front hole 28 mm (1.1)

**Example** - Here is an example showing an Aluminium boat more commonly used on Towing Eye (Aluminium) boats. In this case the difference is the post angle. There are heaps of different posts out there. Here the more vertical post (with the same winch platform) allows the roller to sit up against the bow with the latch not too far forward. The Roller Extender allows a 'quick fix' without cutting, boring or welding.

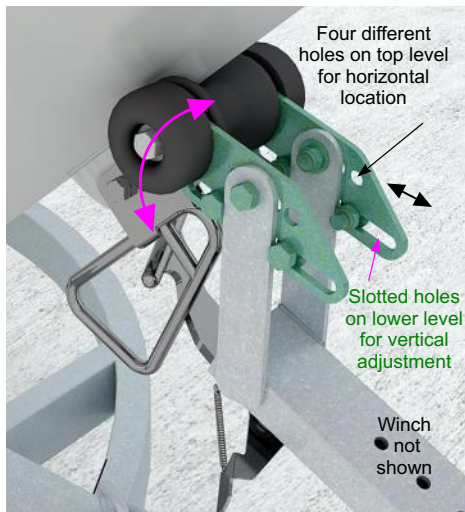

**Roller Extender - option**



Used where the roller needs to be able to project out further to the bow. More commonly required on Towing Eye (Aluminium) boats. There are 4 adjustment horizontal positions. The bolts locate in one of these and the other pair of bolts go in slotted holes, allowing the roller/wedge to swing up/down for vertical adjustment. The 2 lower bolts are fixed so that the bolt or nut heads are located against the vertical Roller supports of the winch platform, as shown, limiting movement.

Roller Extender parts highlighted in green

## 7 Changing the Winch Post or Winch Platform

A range of winch platforms from Roadmaster Boat Trailers (US)

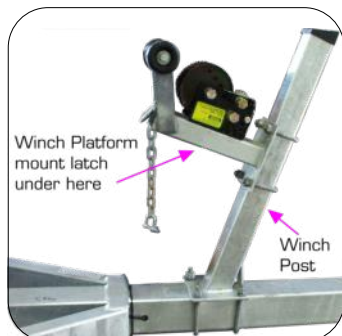

This set up is fine, but there are a number that pose challenges in that they do not have room to mount the Latch and/or they have unusual angles.

Fortunately nearly all trailers use a demountable system and in a few minutes you can remove the winch post/platform and replace it.



There are options specifically made by Easytow Boat Trailers ([www.easytow.com.au](http://www.easytow.com.au)) to suit the L & R Boat Latch.

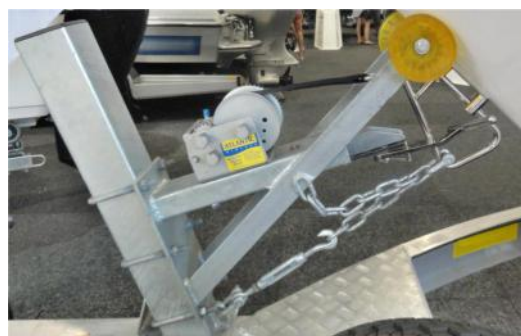

Here we see a quite different style of winch post, where a Latch Support (not our standard one) has been inserted into the tube section under the winch and bolted. This allows you to locate the Latch out further so as to reach the Snare.

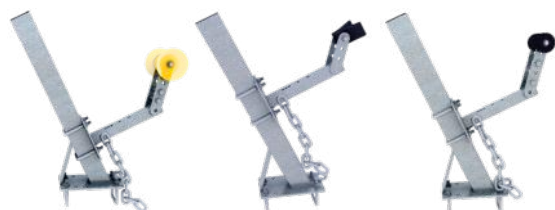

We have a publication "The Right Winch Post & Winch Platform" which provides component detail and a design to produce from. Find on website under "Installation"

## 8 Catamarans



Examples directly above are from...Voyager Catamarans [www.voyagercats.com.au](http://www.voyagercats.com.au)

The L & R Boat Latch is being used on a multitude of catamarans. Some adaptations are needed.



Latch 'support' plate could be stiffer (use channel)

**9 Should you be using a Large Heavy Duty Snare ?**

**Large Heavy Duty Snares**

You have a large boat or a very heavy duty application ?

Release & Retrieve Boat Latch Pty Ltd have released heavy duty snares, intended for boats over 6.5 metres (21 ft).

There is a version for Fibreglass boats and now one for Towing Eye (Aluminium) boats.

**Fibreglass boats**

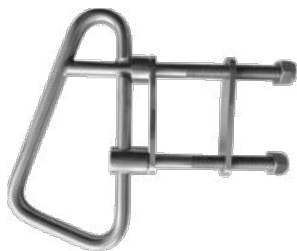

Heavy Duty version

Strength:- 7.5 Tonnes



Standard version

..... 4.7 tonnes

**Towing Eye (Aluminium) boats**



4 hole Standard version

Strength:- .... 4 Tonnes



Heavy Duty version

..... 5 tonnes

Heavy Duty L & R™ fibreglass snare fitted to a Haines Hunter 675 Enclosed.



Haines Hunter

.... and a Cruise Craft fitted with a Heavy Duty L & R™ fibreglass snare.



Cruise Craft

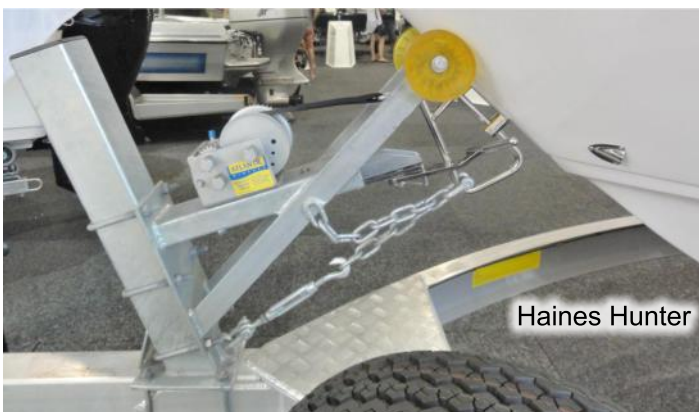

Haines Hunter



Cruise Craft



**10 Examples**

There are some weird and wonderful trailers out there, and some that even don't suit the boat housed on them. Here are a few that present problems in the type of winch platform and post that make it difficult to mount the L & R Boat Latch. Fortunately the winch post is mounted with U-bolts and is easy to remove and change over to another type, with a winch platform that you can remount the winch.



This is an unsafe situation. Commonly found in NZ. In a road accident the boat can project upward in a crash.

The roller should be above the towing eye not below it.

There is no safety chain.

[1]

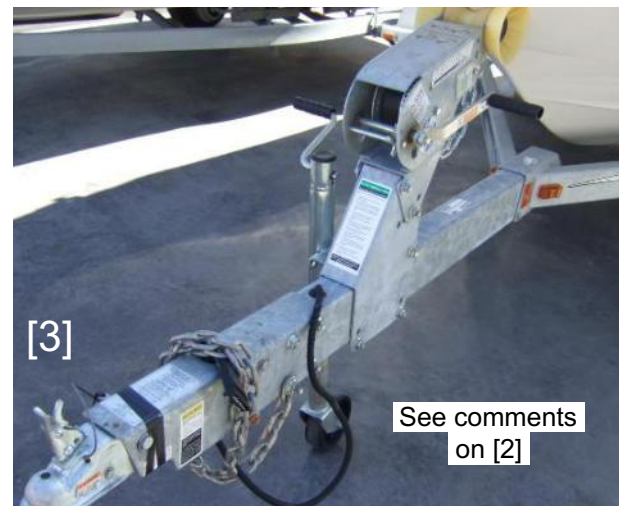

See comments on [2]



[2]

Angle adjustment

Height adjustment

Need to fix in an RHS support here



[4]

Get another Winch Post and Platform.



[5]

Really need to cut off the post top and re-weld it at the back.

Use a 'Latch Support' to provide a mount, point out front

or a new winch post



[6]

Need to remove double roller and use one only. Us and RHS section under winch platform for Latch.

## 10 Examples - USA

Here Sal Cutaia of Myrtle Beach, South Carolina shows how he installed, 3" structural channel aluminum to support the Latch and to use up the space under the winch support.



Trailer:- Loadright Trailers



The Latch has been fixed to a piece of 3" (75mm) aluminium channel, which is then mounted up under the Winch support.



..... to Page 11

## 10 Examples - NZ

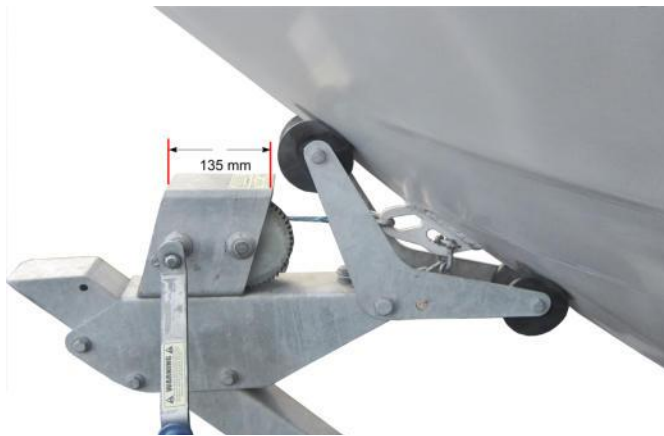

The roller 'wedging' movement and able to stop boat shooting up over the car roof should there be an accident.

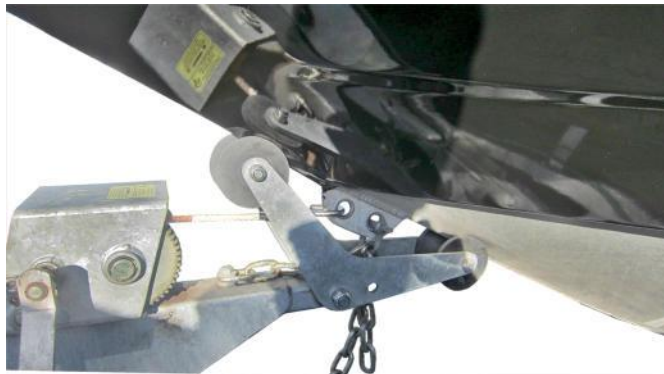

Wedges boat stopping movement

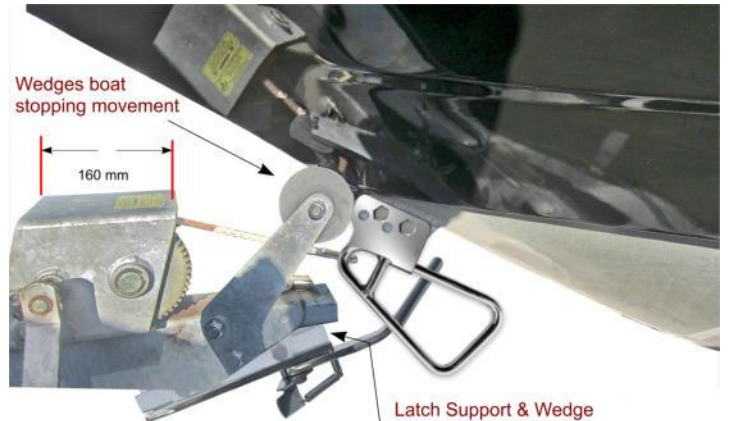

Not really happy with V-blocks that are commonly used in NZ. In an accident there is a danger of launching the boat over onto the car.

It is better to have a rubber roller above the towing eye or where the U-bolt was limit, forward and up/down movement on the trailer.

Not a good solution as the snare may hit the V-block with rough water.

Try the Trailer Shop for winch post and winch platform parts to suit ... [www.thetrailershop.co.nz](http://www.thetrailershop.co.nz)